Operating Instructions for Electrical actuator type AN01



The operating instructions must be read carefully and completely before installation.

- Page 1-4:** Operating instructions for our actuators **S20 – S300**
- Page 5-6:** Additional instructions for **BSR**
- Page 7-8:** Additional instructions for **DPS**
- Page 9:** Additional instructions for **3-Positions**
- Page 10:** Additional instructions for **permanent phase NC / NO**

Product description

The electromechanical J+J quarter-turn actuators are designed to control and regulate industrial valves. For this purpose, the drive has a large number of supporting systems and a freely configurable cam system. In the standard version, the drives are pre-adjusted to 0°-90° (0° = closed / 90° = open). Other working angles are also available. The following manual will guide you through all the necessary steps for installation and operation of the actuator.

Read this manual carefully before installation and commissioning in order to avoid mistakes!

For special models, the enclosed additional instructions and the type label / wiring diagram of the device apply additionally.

Function

The drive automatically detects the connected operating voltage. Depending on the control, it moves in clockwise or counter-clockwise direction into its predefined end position, which is set via the cam system and interrogated by limit switches. The signaling is done before reaching the end position also via the cam system and two other limit switches, which are potential-free interrogated. While the brushless motor drives the main shaft via the gearbox, the DOME position indicator permanently shows the position of the valve. In addition, the operating status is displayed via the multicolored status LED. To prevent condensation in the housing when the outside temperature fluctuates, the actuator has an automatic heater, which protects the interior. **For this, the actuator needs a permanent power supply.**

If the valve is blocked or has a high torque, the electronic torque limiter protects against damage to gear and motor.

In the event of a power failure or emergency intervention, the manual override can be switched on via the changeover switch and the actuator can then be manually turned via the handwheel.

Connections

The mechanical connection is made via a standardized interface according to DIN 3337 / ISO 5211.

For this purpose, each drive has a multi-flange plate and is available with various shaft outputs.

The electrical connection is made via industrial connectors (see connection plug).

Options

Optional functions are available for a wide range of applications (for more information see data sheets):

- **BSR** Battery safety return / **DPS** Digital positioning system / Potentiometer / different wiring options
- **Gold platet end switches** für lastlose Abfrage der Endlagenrückmeldung (z.B. SPS) 0,1A 30VDC

Maintenance

Maintenance work is not necessary on J+J actuators. A regular check of the function is recommended according to the safety requirements of the system, especially for rarely used actuators.

Important instructions



The operating instructions must be read carefully and completely before installation. For special models, the additional instructions are always valid.



When operating electrical devices, certain parts of these devices are inevitably under dangerous voltage. Not noticing the general electrical safety regulations may result in serious personal injury or property damage. Only qualified personnel may work on or near these devices. The staff must be familiar with all safety instructions and maintenance according with this operating instruction.



The faultless and safe operation of the devices requires proper transport, professional storage, installation and assembly as well as careful operation and maintenance.

Notes for planning

Before using the electric actuator, all circumstances relating to the connection, fitting and surrounding area must be clarified. Otherwise long-term damage or a functional failure may occur.

Environment and installation position

Do not install J+J actuators overhead (flange upwards).

It is always important to pay attention to the accessibility of the manual override and visibility of position indicator and status LED. In applications with vibrations in the pipeline, line compensators shall be installed.

If actuators are used outdoor, adequate protection (roofing) against climatic influences must be provided. Strong sunlight can damage the drive due to heat development and UV radiation. Icing of the drive can lead to the unusability of the manual override. To avoid condensation, the internal heater must always be active (see electrical connection).

Commissioning

Mounting on the valve

Taking the medium and pressure into account, as well as after multiplication with a sufficient safety factor, the torque of the valve may never exceed the rated torque of the drive. Before mounting, any end stops of the valve must be removed. If the shaft or flange pattern of the valve can not be directly mounted with the drive, corresponding adaptations are needed. The shaft of the valve may never be longer than the insertion depth of the actuators output. The assembly can be done with grub screws, ensuring a sufficient screwing depth in the drive. In addition, care must be taken during assembly to align the valve and actuator. In this case, it can be helpful to bring the alignment by using the manual override (see manual override). Depending on the valve, the working angle may need to be adjusted (see adjustment of cam system).

Electric connection

The connection may only be made by electrically trained specialist personnel. The general electrical safety rules and VDE regulations apply.

The connection is made with the supplied industrial connectors. While wiring always take care of a correct cable diameter, otherwise the degree of protection IP67 is not guaranteed.

Each plug is fastened to the quarter-turn actuator with a screw, it must not be over-tightened.

J+J quarter-turn actuators must be connected with a single phase and controlled via relays or switches.

Depending on requirements, three different wiring methods without reconfiguration are available for the control.

Due to the internal power supply, the actuator can be viewed as a capacitive load.

Accordingly, an external fuse with appropriate **trigger characteristics (e.g. circuit breaker type D)** must be provided.

Switching contacts should have a **suitable contact material (e.g. silver-tin oxide AgSnO)** or a zero voltage switch.

No external consumers should be connected parallel to the actuator.

Connection plugs

		big plug	small plug
Max. cable diameter		8mm -10,5mm	5mm - 6mm
Type		DIN EN175301-803 Form A	Industrial connector type C

		Versorgungsstecker supply plug	Endlagenstecker end position plug
AC/DC		<p>Regelung 3 Punkt regulation 3 point Schaltbild zeigt Ansteuerung in offene Richtung Wiring diagram shows control to opened direction</p> <p>Pin2 (A)= ZU / CLOSE Pin3 (B)= AUF / OPEN Pin2+3 (A+B)= STOP</p>	<p>Anschluss connection</p> <p>GESCHLOSSEN / OFFEN CLOSED / OPENED</p>
DC		<p>Steuerung 2 Draht control 2 wires</p>	<p>Interne Funktion internal function</p> <p>Ansicht in geöffneter Position View of opened position</p> <p>OFFEN / GESCHLOSSEN OPENED / CLOSED</p>

- 1 Sealing
- 2 Terminal block
- 3 Clamp
- 4 Housing
- 5 Sealing ring
- 6 Clamp ring
- 7 screw-in pod
- 8 Washer
- 9 Screw
- 10 Sealing washer

A Supply plug
B Option
C End position plug

Overview

Description

20-35-55-85

140-300

- A Switch manual override
- B Handwheel
- C DOME position indicator
- D Status LED
- E Wiring diagram
- F Type label

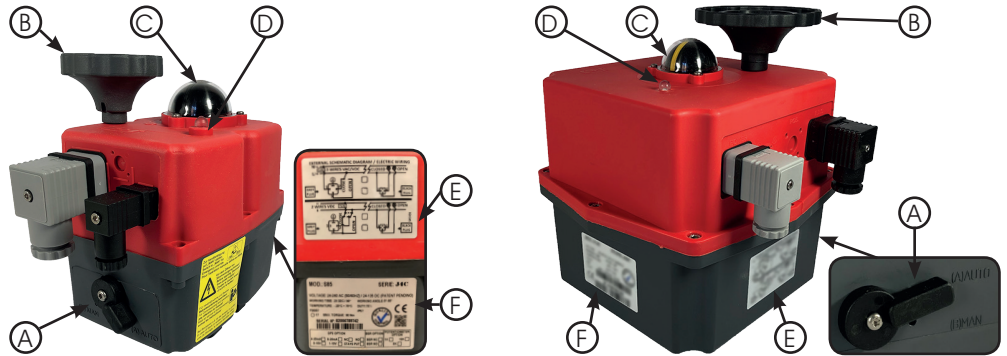

All models:

Duty cycle	Temperature range	Heater	Protection IEC60529	2x End position switches
ED= 75%	-20°C - +70°C	3,5 W	IP67	SPST NO 5A 125VAC / 3A 250VAC

Optional 0,1A 30VDC (see page 1)

Model specific:

Model	Current consumption with max. torque Voltage range: 24-240V AC (50/60Hz) / 24-135 DC				Work- / Break torque	Working time without load s/90° ±10%	Weight
	24V AC	24V DC	110V AC	230V AC			
S 20	1,3A / 30,7W	1,0A / 23,4W	0,3A / 32,7W	0,2A / 46W	20Nm / 25Nm	10s (5,5s)	1,8kg
S 35	1,7A / 40,2W	1,4A / 32,8W	0,4A / 41,9W	0,2A / 46W	35Nm / 38Nm	10s	1,9kg
S 55	2,0A / 47,5W	1,6A / 39,0W	0,4A / 47,0W	0,2A / 46W	55Nm / 60Nm	13s	2,4kg
S 85	1,5A / 36,0W	1,2A / 29,3W	0,3A / 36,5W	0,2A / 46W	85Nm / 90Nm	29s	3,0kg
S140	3,3A / 79,2W	2,5A / 60,7W	0,7A / 78,7W	0,4A / 105,6W	140Nm / 170Nm	25s	5,2kg
S300	3,3A / 79,2W	2,7A / 64,7W	0,8A / 84,7W	0,5A / 113,5W	300Nm / 350Nm	48s	5,2kg

Operation

Status LED (D)

Operation status	LED									
Without power supply	Grey	Grey	Grey	Grey	Grey	Grey	Grey	Grey	Grey	Grey
Actuator is in opened position	Green	Green	Green	Green	Green	Green	Green	Green	Green	Green
Actuator is in closed position	Red	Red	Red	Red	Red	Red	Red	Red	Red	Red
Actuator is in stop position	Purple	Purple	Purple	Purple	Purple	Purple	Purple	Purple	Purple	Purple
Actuator is turning in open direction	Yellow	Green	Yellow	Green	Yellow	Green	Yellow	Green	Yellow	Green
Actuator is turning in close direction	Yellow	Red	Yellow	Red	Yellow	Red	Yellow	Red	Yellow	Red
Torque limiter active in open direction	Green	Green	Green	Green	Green	Green	Green	Green	Green	Green
Torque limiter active in close direction	Red	Red	Red	Red	Red	Red	Red	Red	Red	Red
Manual override active, motor was stopped	Yellow	Yellow	Yellow	Yellow	Yellow	Yellow	Yellow	Yellow	Yellow	Yellow

Manual override (A/B)

All J4C models have a manual emergency transmission for manual operation in case of a power failure. For manual override turn the switch „AUTO-MAN“ (A) to „MAN“. This decouples the motor from the gear.

Now you can turn the actuator with the handwheel (B).

After about four times of the working time, the motor is automatically stopped by the electronics.

To put the actuator back in automatic mode after manual actuation, turn the switch „AUTO-MAN“ (A) to the „AUTO“ position.

Now the motor is coupled again. If the motor has switched off automatically, this can be reversed either by driving to the other direction or by reactivating with a short power interruption (removal of the power plug).



The switch „AUTO-MAN“ must not be turned over its predetermined switch positions. If the switching is difficult, the gear can be synchronized by using the handwheel. The screw of the switch must never be loosened!

Adjustment of the cam system

With the cam system, the working angle as well as the end position feedback of the actuator can be adjusted. The drive is pre-adjusted ex works (see type label). Depending on application, valve, lack of alignment or adapters, it may be necessary that the drive has to be adjusted in its travel.



All work on the opened actuator must be under protective extra-low voltage or without any voltage applied and carried out by appropriately qualified personnel. Not complying with the general Electro safety rules can result in serious injury or property damage.

1. Open the housing

Needed tools: Allen Key 3mm (Models 35-300), Torx key T20

To adjust the cam system, the housing must first be opened. Particular care should be taken to ensure that all sealings and screws are carefully stored. The following steps have to be carried out:

- Unscrew all plugs (watch the plugs sealing)
- Loosen screw in handwheel and pull handwheel upwards
- Loosen and remove the housing screws
- Remove the cover (observe the circumferential housing seal, as well as the shaft seal and snap ring of the handwheel)
- Lay the cover aside (cables can remain connected to the board) and pay attention to the original cable routing
- Put handwheel back on (to turn it while adjusting the cams)

2. Adjusting the cams

For adjustment, first the adjusting tool is needed, which is attached to the motor. To adjust a cam, the tool needs to be plugged in it, as shown in the picture „plugged in tool“. By turning the tool, the cam can now be adjusted.

Volt free end position feedback	
Cam 1 (green)	Position „open“
Cam 2 (red)	Position „close“

Motor shutdown	
Cam 3 (green)	Position „open“
Cam 4 (red)	Position „close“

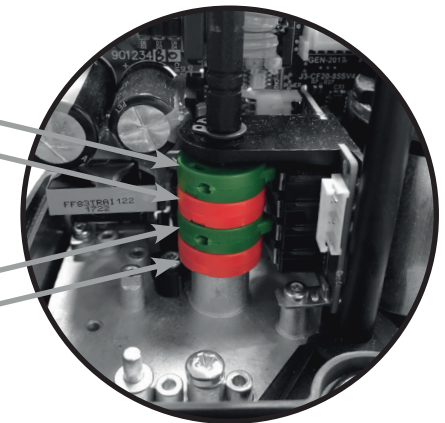

Plugged in tool

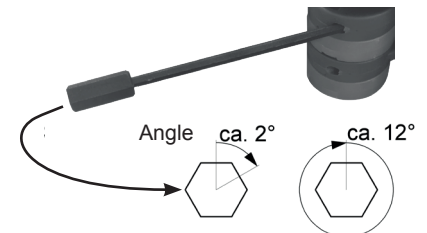

Proceeding: The Actuator is first switched from AUTO to MAN.

The position to be set is then approached by handwheel.

Now the adjusting tool is plugged in the respective cam and is twisted until the click sound of the microswitch is heard. The cam must always be turned to the switch from the direction which the main shaft will move in electrical operation to this position. The end position feedback is set to switch shortly before reaching the end position. The correct setting of the cam positions must always be checked with an electrical test drive (use safety extra-low voltage). The end positions can be measured with a continuity tester on the plug (see wiring diagram).

3. Close the housing

After completing the adjustment, the actuator can be closed again by reversing the steps described under point 1 in reverse order. Particular care must be taken to ensure that all screws, seals, individual parts and the internal cable routing are returned to their original position.

Troubleshooting

The actuator moves and then stops. The operating LED flashes red or green (see status LED).

- » High torque on the valve due to not removed end stops or solids in the valve. Valve must be checked!
- » Model size of the actuator is too small.

The actuator is in position „open“ but the valve is closed or half opened.

- » Actuator is mounted on the valve with a wrong angle. Dismount, turn the actuator in manual mode to correct angle, mount it.

The limit switches for end position feedback do not work.

- » Check the wiring. Check the adjustment of the cams so that they trigger shortly before reaching the end position.
- » In load-free interrogation of the limit switch, soot is formed inside. Actuator with gold contact switches are to be used.

The actuator moves, but the valve does not.

- » The connection between actuator and valve is damaged or incorrectly dimensioned.

For other malfunctions, please contact our technical service department.



This additional manual is a supplement to the short manual J4C.
It only describes deviating functions and properties, which are accompanied by the BSR.
 Information on operating an actuator with DPS and BSR can be found at the end of this manual.
 The J4C Manual must be observed! To open the drive, follow the description under the item „Cam system adjustment instructions“ in the J4C Manual.



The manual must be read carefully and completely before installation !



When operating electrical devices, certain parts of these devices are inevitably under dangerous voltage. Not noticing the general electrical safety regulations may result in serious personal injury or property damage. Only qualified personnel may work on or near these devices. The staff must be familiar with all safety instructions and maintenance according with this operating instruction.

Description

With the BSR, the actuator moves into its default safety position in the event of a power failure. The safety position can be configured as open (NO) or closed (NC) (see configuration).
This safety function is realized by a battery in the actuator, therefore the actuator must always be permanently supplied with voltage.
 The battery is pre-charged, to ensure the safety function, but the actuator must be charged before commissioning for the duration of the „charging time for 100% battery charge“ (see technical data). While the actuator travels by the battery, the internal heater and the torque protection are not active.
 After turning via BSR, the drive indicates with its flashing LED for approx. 3 minutes that it has moved to its safety position due to a lack of supply voltage (see status light). As soon as the actuator gets power again it is immediately ready for use.

Electric connection

For the electric connection and wiring, follow the instruction of the manual J4C.

Operation

Status LED:

Operation status	LED
Actuator without power supply, BSR NO active	Green LED on
Actuator without power supply, BSR NC active	Red LED on
Battery protection! It needs to be recharged.	Yellow LED on

Function test:

A regular function test according to the safety requirements needs to be done.
To avoid unintentional opening or closing, it may be necessary to disassemble the actuator from the valve during the test!
 The function test is done as following:

1. With your control or the manual mode of the actuator, move it in the opposite position of the safety position.
 (BSR NO: Turn the actuator in closed position / BSR NC: Turn the actuator in opened position)
2. Turn off the power and simulate power failure (if necessary, switch the actuator to automatic mode again)
3. Actuator moves to its safety position via BSR, after which it flashes for about 3 minutes to indicate the activated BSR
4. After this time, the LED should be permanently off and the actuator should remain in its safety position
5. Test completed, the actuator can be put back into operation by applying the supply voltage

Overview

Description	20-35-55-85	140-300
A BSR circuit board B Battery C battery holder D Jumper „seldir“		

Configuration NC / NO

To open the actuator, follow the description under the topic „Adjustment of the cam system“ in the J4C manual. The configuration has to be made without any power supplied.

For this the jumper „seldir“ (D) is removed or put on:

Jumper removed: NO (Actuator turns to opened position in case of a power failure)
 Jumper put on: NC (Actuator turns to opened position in case of a power failure)

Now the actuator can be closed again (pay attention to J4C manual). After that, the function is tested as described under „function test“ in this manual.

Technical data

Model	20	35	55	85	140	300
Charging time for 100% charge	28 h				54 h	
Maximum turns with full battery charge	5				4	
Reload time per BSR activation	15 min	21 min	48 min	58 min	30 min	50 min
Power consumption at BSR activation	2,2 W	3,0 W	6,8 W	8,3 W	23 W	
Current consumption at BSR activation	10,1 mA	14,0 mA	31,6 mA	38,6 mA	15,1 mA	25,7 mA
Battery load ±10%	2200 mAh				4400 mAh	
Charging current	40 mA					
Weight	0,27 kg				0,38 kg	

Combinations

Combination with DPS or Potentiometer

DPS: The position of the actuator can be controlled, it gives out its actual position and turn to the safety position (NC, NO) in case of a power failure.

Potentiometer: The actuator drives open/close, gives its actual position as an ohmic value and turns to the safety position (NC, NO) in case of a power failure.

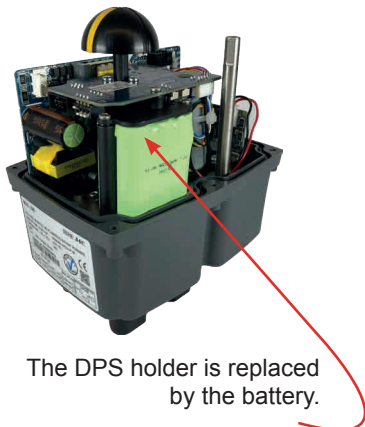

3 Positions

The actuator has the possibility to drive to a middle position, but this cannot be chosen as the BSR safety position.





This additional manual is a supplement to the short manual J4C.

It only describes deviating functions and properties, which are accompanied by the DPS.

Information on operating a drive with DPS and BSR can be found in the additional manual BSR.

The J4C Manual must be observed! To open the drive, follow the description under the item „Cam system adjustment instructions“ in the J4C Manual.



The manual must be read carefully and completely before installation !



When operating electrical devices, certain parts of these devices are inevitably under dangerous voltage. Not noticing the general electrical safety regulations may result in serious personal injury or property damage. Only qualified personnel may work on or near these devices. The staff must be familiar with all safety instructions and maintenance according with this operating instruction.

Description

With the DPS, the actuator can be freely positioned within its working angle via the input signal.

In addition, it gives its actual position permanently as an output signal back.

The input and output signal can be configured as desired: 4-20mA, 0-10V, 1-10V

In addition, the position can be set if there is no input signal (0mA, 0V): NC (closed), NO (open)

If these settings need to be changed, the topic „Adjustment and configuration“ must be followed.

To change the working angle, it must first be set via the cam system (see Manual J4C).

The input signal must be connected potential-free!

Commissioning

Electrical connection

The connection may only be carried out by electrically trained specialist personnel.

The general electrical safety rules and VDE regulations apply.

The connection is made with the supplied industrial connectors. While wiring always take care of a correct cable diameter (see Manual J4C) and the plug seal, otherwise the degree of protection IP67 is not guaranteed. Each plug is fastened to the quarter-turn actuator with a screw, it must not be over-tightened.

An external fuse with appropriate tripping characteristic for motors (for example circuit breaker type C) shall be provided.

No external consumers should be connected parallel to the actuator.

Connection plugs

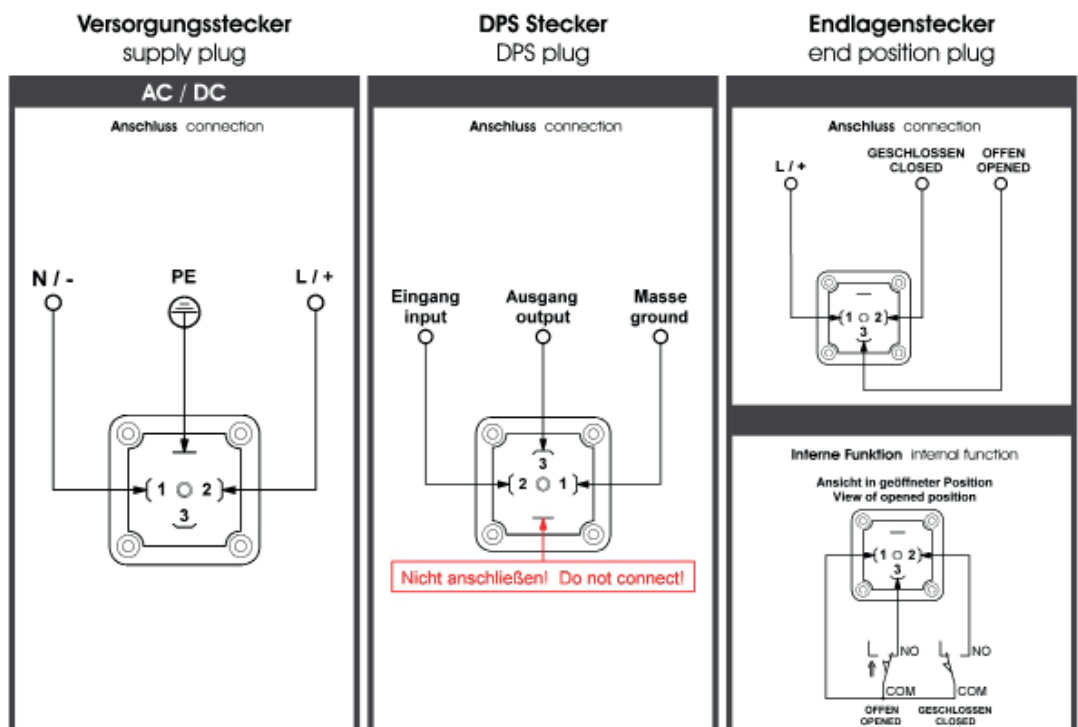
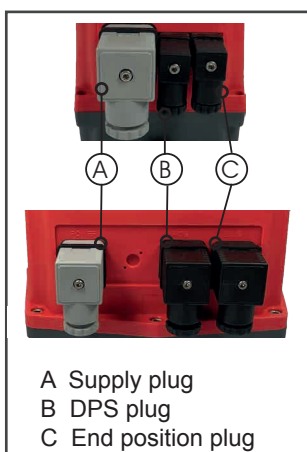

Overview

Description	20-35-55-85	140-300
A DPS board B DPS board support C Connector DPS Terminal D Dipswitches		

All models:

Precision	Linearity	Hysteresis	Impedance Input mA	Impedance Input V
3%	2%	3%	100 Ω	25 kΩ

Steps for 90°:

4-20mA	0-10V	0-20mA	1-10V	Class
min. 150 Steps/90°	min. 98 Steps/90°	min. 150 Steps/90°	min. 87 Steps/90°	B+C to E DIN EN 15714 Inching + Modulation

Operation

Status LED:

Operation status	LED
Actuator is in target position	
Actuator is turning in open direction	
Actuator is turning in close direction	
Actuator is turning without input signal (4-20mA or 1-10V)	
Input signal is too high (>20mA or >10V)	
Self adjustment	

Adjustment and Configuration

To open the actuator, follow the description under the topic „Adjustment of the cam system“ in the J4C manual.

In order to change the working angle, first follow the „Adjustment of the cam system“ (see J4C manual). Now follows the self-adjustment * of the DPS, in which the actuator approaches both end positions of the cam system one after the other.

* For drives with BSR, the battery must be removed from the BSR board before self-adjustment.

Self-adjustment with opened actuator:

1. Turn off the power supply
2. Put dipswitch 1 to on / 2,3,4 to off
3. Turn on the actuator, then put dipswitch 1 to off again
4. The actuator will do its self-adjustment.

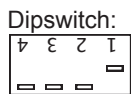

Self-adjustment from outside:

1. Turn off the power supply
2. Connect Pin1+Earth (Plug B)
3. Turn power on and remove the connection
4. The actuator will do its self-adjustment.

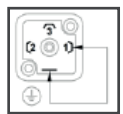

Configuration of input signal:

1. Turn off the power
2. Configure the dipswitches
3. Turn on the power

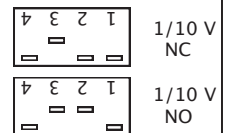
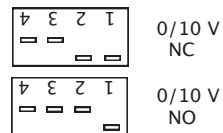
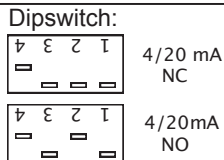

Troubleshooting

The actuator does not turn to the correct position.

The cams were adjusted, but it drives to the positions from before.

- » Make a self-adjustment of the actuator.

The actuator reacts in the wrong direction. (e.g. 0V = opened)

- » The valve was mounted in wrong position or the configuration needs to be changed (NO or NC)

For other malfunctions, please contact our technical service department.



This additional manual is a supplement to the short manual J4C.
It only describes the deviating wiring, which is accompanied by the 3 positions option.
 The J4C Manual must be observed! To open the actuator, follow the description under the item „Cam system adjustment instructions“ in the J4C Manual.



The manual must be read carefully and completely before installation !



When operating electrical devices, certain parts of these devices are inevitably under dangerous voltage. Not noticing the general electrical safety regulations may result in serious personal injury or property damage. Only qualified personnel may work on or near these devices. The staff must be familiar with all safety instructions and maintenance according with this operating instruction.

Description

Due to the 3-position wiring option, the actuator has the possibility to drive to an additional middle position. Thus, for example, 3 different positions of a 3-way ball valve can be used. The middle position is not signalized by the end position feedback. To evaluate the current position of the actuator are the Options „Potentiometer“ or „DPS only output signal“ available.

In the standard version, the actuator is pre-adjusted to 0°-90°-180°. Special working angles must be specified when ordering. To change the working angle yourself, follow the topic „Cam System Adjustment“ in the manual J4C. To adjust the middle position, an additional orange cam is installed in the actuator.

Commissioning

Electric connection

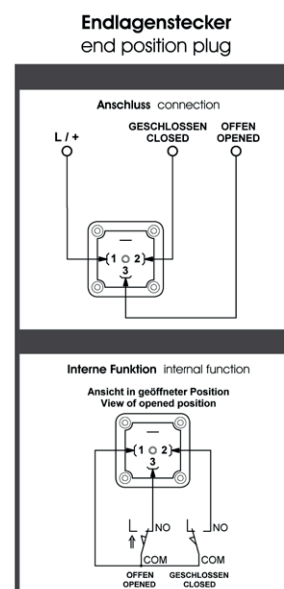
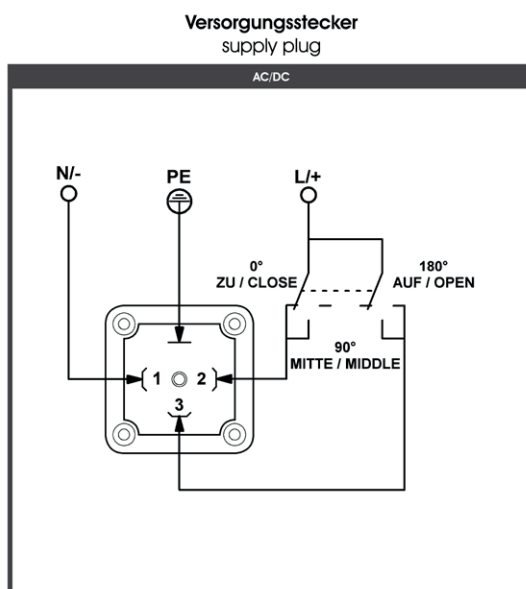
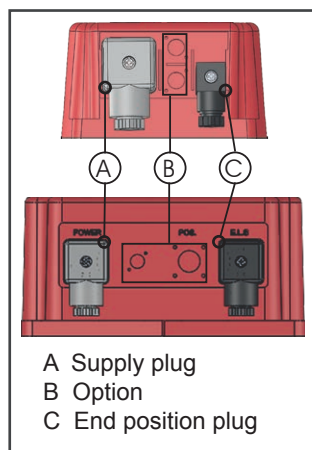

Operation

Status LED: **Further operating states can be found in the manual J4C**

operation status	LED
Actuator is in opened position (0°)	Green
Actuator is in middle position (90°)	Yellow
Actuator is in closed position (180°)	Red



This additional manual is a supplement to the short manual J4C.

It only describes the deviating wiring, which is accompanied by the permanent phase option.

The J4C Manual must be observed! To open the actuator, follow the description under the item „Cam system adjustment instructions“ in the J4C Manual.



The manual must be read carefully and completely before installation !



When operating electrical devices, certain parts of these devices are inevitably under dangerous voltage. Not noticing the general electrical safety regulations may result in serious personal injury or property damage. Only qualified personnel may work on or near these devices. The staff must be familiar with all safety instructions and maintenance according with this operating instruction.

Description

With the permanent phase NO / NC wiring, the actuator is permanently supplied with voltage via a wire. By switching the second wire, the actuator moves in the opposite direction. The actuator must be connected single phase!

The desired variant (NC or NO) must be specified when ordering, as no subsequent reconfiguration is possible.

This wiring is mainly used as:

Replacement to solenoid valve (low wiring costs), additional security (in case of failure of the control), etc.

Commissioning

Electric connection

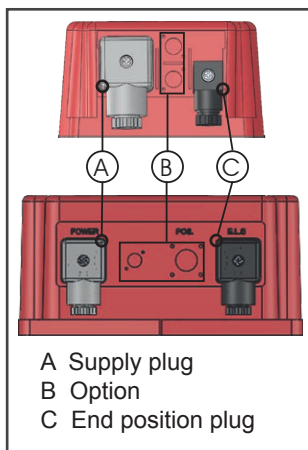

Versorgungsstecker
supply plug

Endlagenstecker
end position plug

